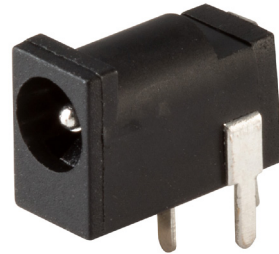

MODEL: PJ-007 | **DESCRIPTION:** DC POWER JACK

FEATURES

- PCB mount
- non-shielded

SPECIFICATIONS

parameter	conditions/description	min	typ	max	units
rated input voltage			24		Vdc
rated input current				3.5	A
contact resistance				50	mΩ
insulation resistance	at 500 Vdc	100			MΩ
voltage withstand				500	Vac
insertion/withdrawal force		0.3		3	kg
operating temperature		-20		85	°C
life			5,000		cycles
flammability rating	UL94V-0				
RoHS	yes				

SOLDERABILITY

parameter	conditions/description	min	typ	max	units
wave soldering	dipped in solder pot for 5 ±0.5 seconds	255	260	265	°C

MECHANICAL DRAWING

units: mm
 tolerance:
 X.X ±0.50 mm
 X.XX ±0.30 mm
 X.XXX ±0.15 mm
 PCB: ±0.05 mm
 unless otherwise specified

DESCRIPTION	MATERIAL	PLATING/COLOR
center pin	brass	CuSn
terminal 1	brass t=0.40	silver
terminal 2	stainless steel t=0.20	silver
terminal 3	brass t=0.40	silver
cover	PA10T (UL94V-0)	black
housing	PA10T (UL94V-0)	black

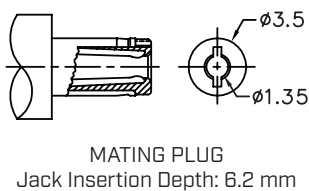
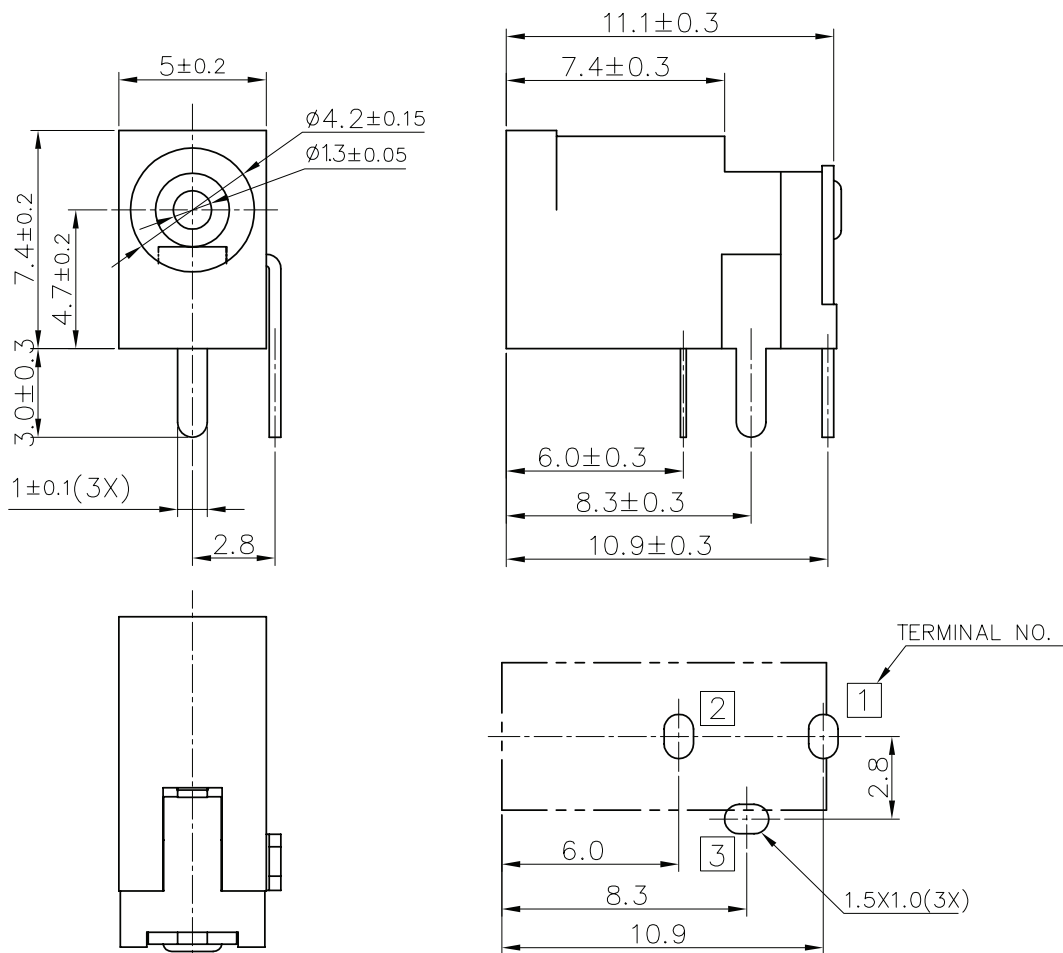

SCHEMATIC	
Model	PJ-007
Center Pin	$\phi 1.30$ mm

REVISION HISTORY

rev.	description	date
1.0	initial release	04/17/2006
1.01	applied new template	02/13/2012
1.02	brand update	04/02/2020
1.03	updated housing mold, changed terminal plating	07/01/2020
1.04	logo, datasheet style update	08/05/2022
1.05	product reengineered for improved manufacturability and production yield, see PCN for details	01/17/2023
1.06	product reengineered for improved manufacturability and production yield, see PCN for details	04/24/2024

The revision history provided is for informational purposes only and is believed to be accurate.



CUI Devices offers a one (1) year limited warranty. Complete warranty information is listed on our website.

CUI Devices reserves the right to make changes to the product at any time without notice. Information provided by CUI Devices is believed to be accurate and reliable. However, no responsibility is assumed by CUI Devices for its use, nor for any infringements of patents or other rights of third parties which may result from its use.

CUI Devices products are not authorized or warranted for use as critical components in equipment that requires an extremely high level of reliability. A critical component is any component of a life support device or system whose failure to perform can be reasonably expected to cause the failure of the life support device or system, or to affect its safety or effectiveness.

cuidevices.com