

**MODEL:** CPI-3116-3-100T | **DESCRIPTION:** PIEZO BUZZER INDICATOR

**FEATURES**

- 3 Vdc rated
- 97 dB
- continuous tone



**SPECIFICATIONS**

parameter	conditions/description	min	typ	max	units
rated voltage			3		Vdc
operating voltage		2.5		3.5	Vdc
current consumption				30	mA
rated frequency	at rated voltage	2,700	3,200	3,700	Hz
sound pressure level	at 30 cm, rated voltage	97			dB
tone	continuous				
dimensions	Ø31.0 x 16.4				mm
weight				7.8	g
material	PBT+15%GF UL 94V-0 (black)				
terminal	pins (tin plating)				
operating temperature		-35		80	°C
storage temperature		-40		85	°C
washable	no				
RoHS	yes				

Notes: 1. All specifications measured at 5-35°C, humidity at 45-85%, under 86-106kPa pressure, unless otherwise noted.

**SOLDERABILITY**

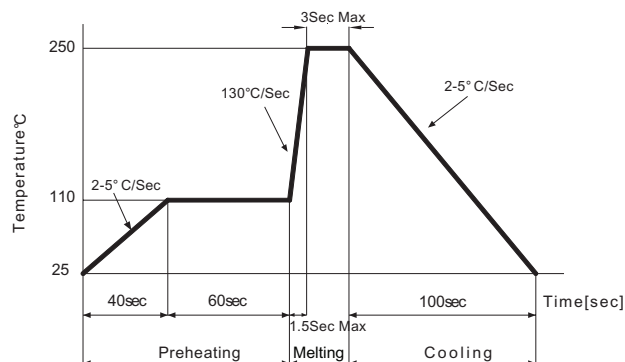
parameter	conditions/description	min	typ	max	units
hand soldering	for maximum 2 seconds	330		380	°C
wave soldering	see recommended wave soldering profile			250	°C



## MECHANICAL DRAWING

units: mm  
tolerance: ±0.5 mm

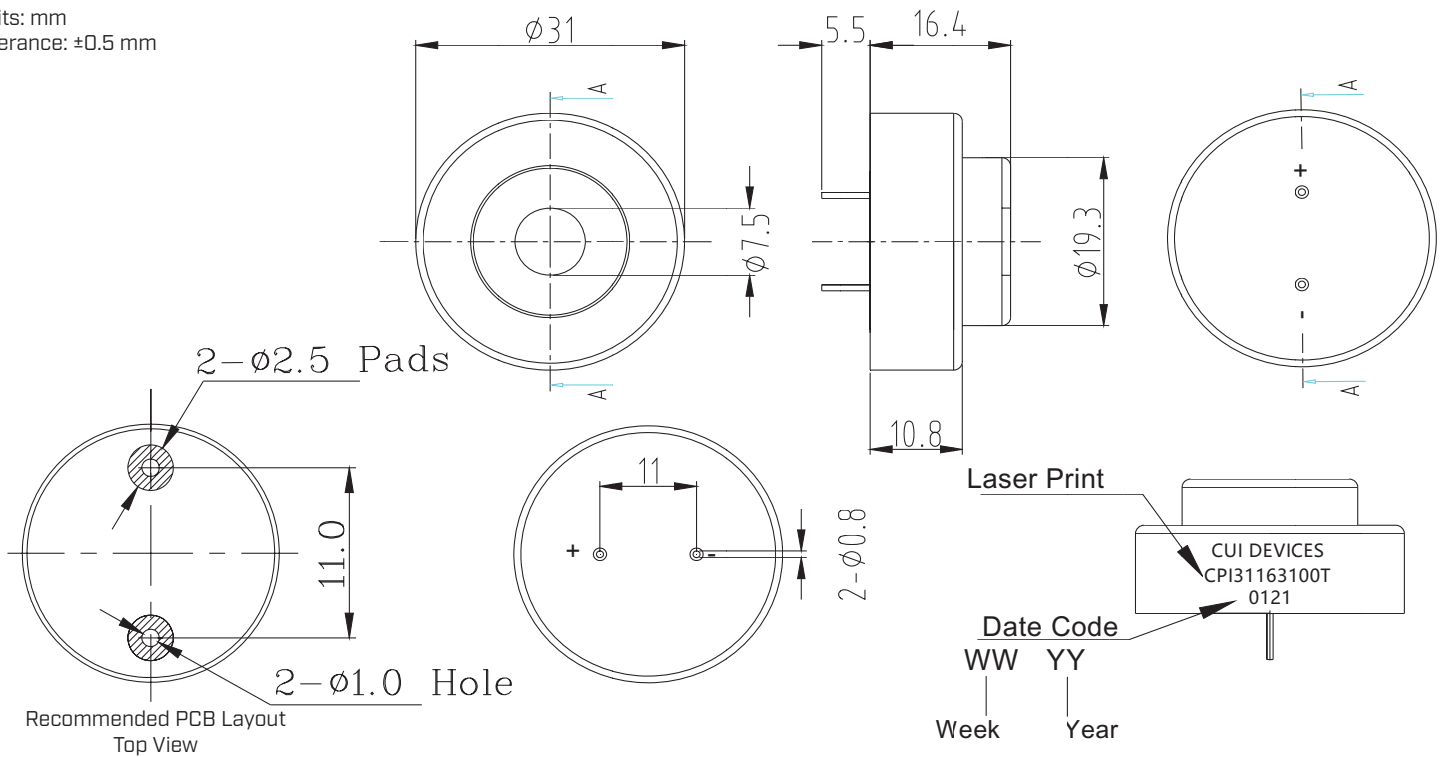

## PERFORMANCE CURVES

P: Voltage vs. Sound Pressure Level  
I: Voltage vs. Current Consumption

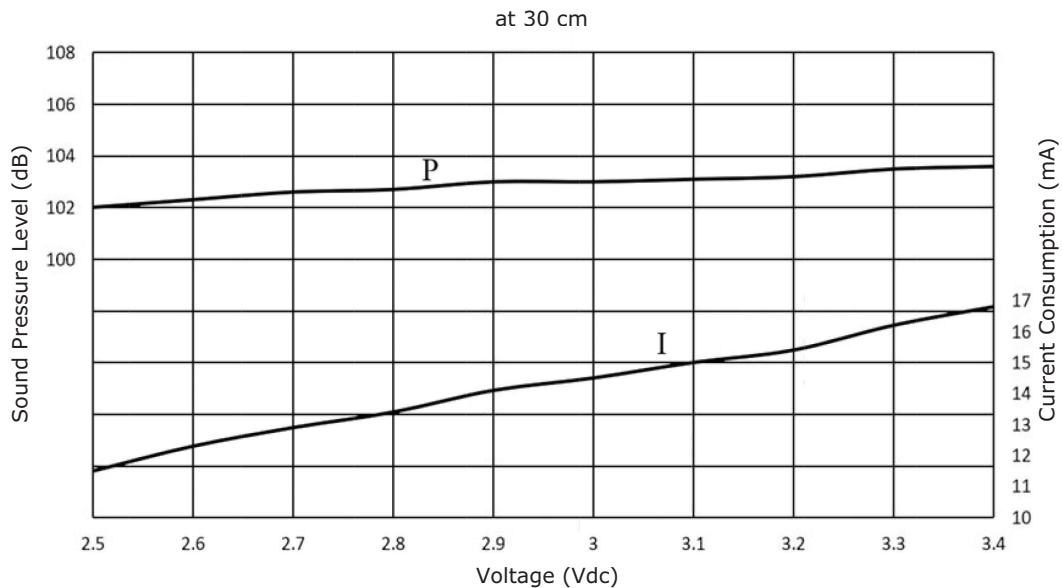

## PACKAGING

units: mm

Inner Box Size: 310 x 248 x 49 mm  
 Inner Box QTY: 140 pcs per box  
 Carton Size: 550 x 330 x 290 mm  
 Carton QTY: 1,400 pcs per carton

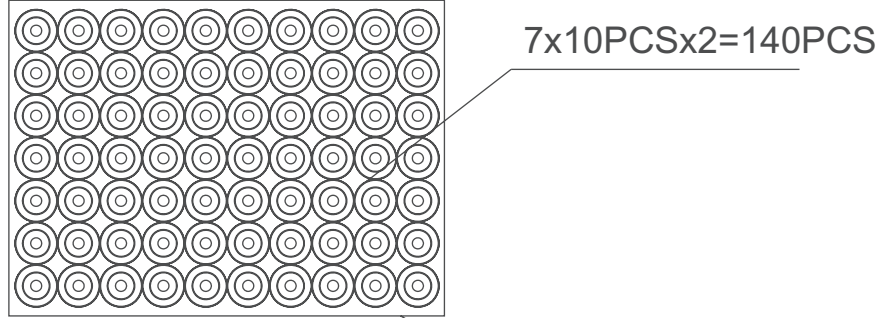

Out Box

Lot No.	XXXXXXXXXX
Part No.	XXXXXXXXXX XXXXXXXXXX
Quantity.	XXXX Pcs
Date:	WW YY
	MADE IN CHINA
	CUI DEVICES

RoHs Compliant

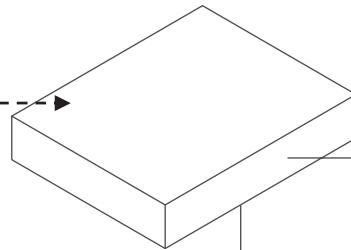

Out Box

Carton Box  
(10PCS Out Box)

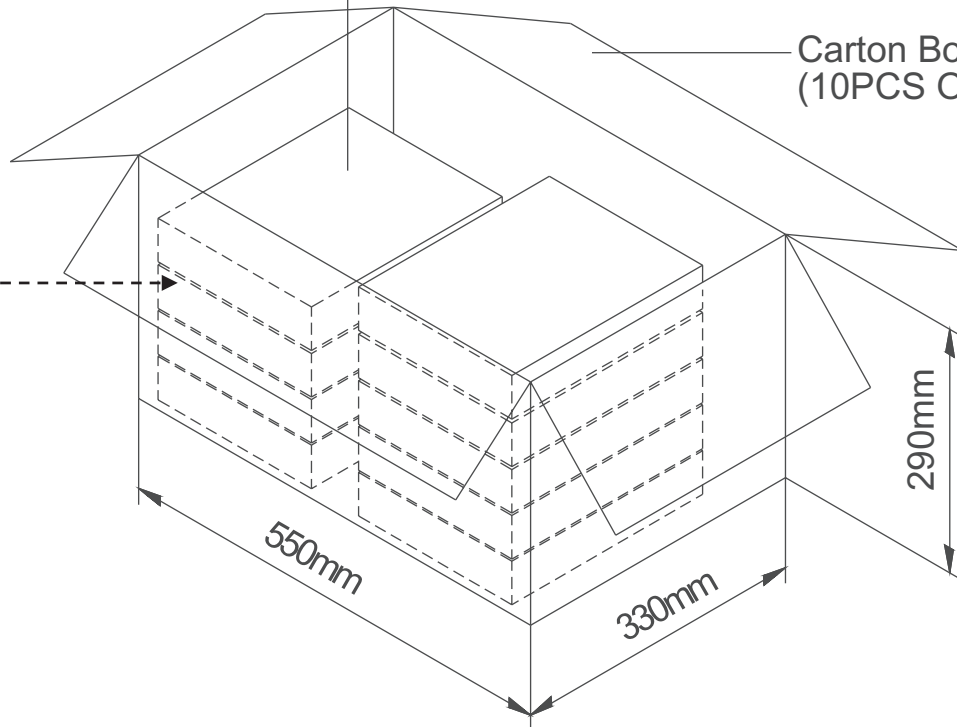

## REVISION HISTORY

rev.	description	date
1.0	initial release	11/23/2021
1.01	logo, datasheet style update	08/05/2022

The revision history provided is for informational purposes only and is believed to be accurate.



CUI Devices offers a one (1) year limited warranty. Complete warranty information is listed on our website.

CUI Devices reserves the right to make changes to the product at any time without notice. Information provided by CUI Devices is believed to be accurate and reliable. However, no responsibility is assumed by CUI Devices for its use, nor for any infringements of patents or other rights of third parties which may result from its use.

CUI Devices products are not authorized or warranted for use as critical components in equipment that requires an extremely high level of reliability. A critical component is any component of a life support device or system whose failure to perform can be reasonably expected to cause the failure of the life support device or system, or to affect its safety or effectiveness.

[cuidevices.com](http://cuidevices.com)