

**SERIES:** AMT10E | **DESCRIPTION:** MODULAR INCREMENTAL ENCODER

**FEATURES**

- patented capacitive ASIC technology
- low power consumption
- CMOS outputs
- 16 DIP switch selectable resolutions
- index pulse
- modular package design
- straight (radial) and right-angle (axial) versions
- 9 mounting hole options for radial version
- 8 mounting hole options for axial version
- -40~100°C operating temperature

**ELECTRICAL**

parameter	conditions/description	min	typ	max	units
power supply	VDD	3.1	5	5.5	V
current consumption	with unloaded output		6		mA
output high level		VDD-0.8			V
output low level				0.4	V
output current	CMOS sink/source per channel			2	mA
rise/fall time			30		ns

**INCREMENTAL CHARACTERISTICS**

parameter	conditions/description	min	typ	max	units
channels	quadrature A, B, and X index				
waveform	CMOS voltage square wave				
phase difference	A leads B for CCW rotation (viewed from front)		90		degrees
quadrature resolutions <sup>1</sup>	120, 240, 250, 312.5, 480, 500, 625, 640, 960, 1000, 1250, 1280, 2000, 2500, 2560, 5120				PPR
index <sup>2</sup>	one pulse per 360 degree rotation				
accuracy			0.25		degrees
quadrature duty cycle (at each resolution)	640, 1280, 2560, 5120	49	50	51	%
	120, 240, 250, 312.5, 480, 500, 625, 960, 1000, 1250	47	50	53	%
	2000, 2500	43	50	56	%

Notes: 1. Resolution selected via adjustable DIP switch, pre-set to 5120 PPR. All resolutions are listed as pre-quadrature, meaning the final number of counts is PPR x 4.  
2. Some stepper motors may leak a magnetic field causing the AMT index pulse to not function properly (non-magnetic version available with 20 pulses per revolution).

## MECHANICAL

parameter	conditions/description	min	typ	max	units
motor shaft length		9			mm
motor shaft tolerance			NOM +0/-0.015		mm
weight	AMT10E2 AMT10E3		20.5 14.0		g g
axial play				±0.3	mm
rotational speed (at each resolution)	480, 960, 1000, 1250, 2000, 2500, 2560, 5120 120, 240, 250, 312.5, 500, 625, 640, 1280			3000 6000	RPM RPM

## ENVIRONMENTAL

parameter	conditions/description	min	typ	max	units
operating temperature <sup>1</sup>		-40		100	°C
humidity	non-condensing			95	%
vibration	20~500 Hz, 1 hour on each XYZ			10	G
shock	11 ms, ±XYZ direction			50	G
RoHS	yes				

Note: 1. Encoders with operating temperature of -40~125°C are available as a custom order

## WAVEFORMS

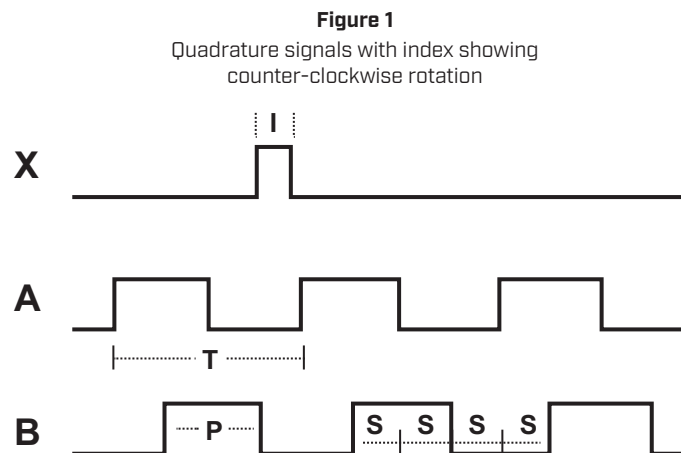

The following parameters are defined by the resolution selected for each encoder. The encoders resolution is listed as Pulses Per Revolution (PPR), which is the number of periods (or high pulses) over the encoders revolution.

Parameter	Description	Expression	Units	Notes
PPR	resolution		Pulses Per Revolution	This is the user selected value and the format all resolutions are listed in
CPR	counts	PPR x 4	Counts Per Revolution	This is the number of quadrature counts the encoder has
T	period	360/R	mechanical degrees	
P	pulse width	T/2	mechanical degrees	
S	A/B state width	T/4	mechanical degrees	This is the width of a quadrature state
I	index width	T/4	mechanical degrees	The width of a once per turn index is the state width for A & B lines

Note: For more information regarding PPR, CPR, or LPR (Lines Per Revolution) view <https://www.cuidevices.com/blog/what-is-encoder-ppr-cpr-and-lpr>

## PART NUMBER KEY

For customers that prefer a specific AMT10E configuration, please reference the custom configuration key below.

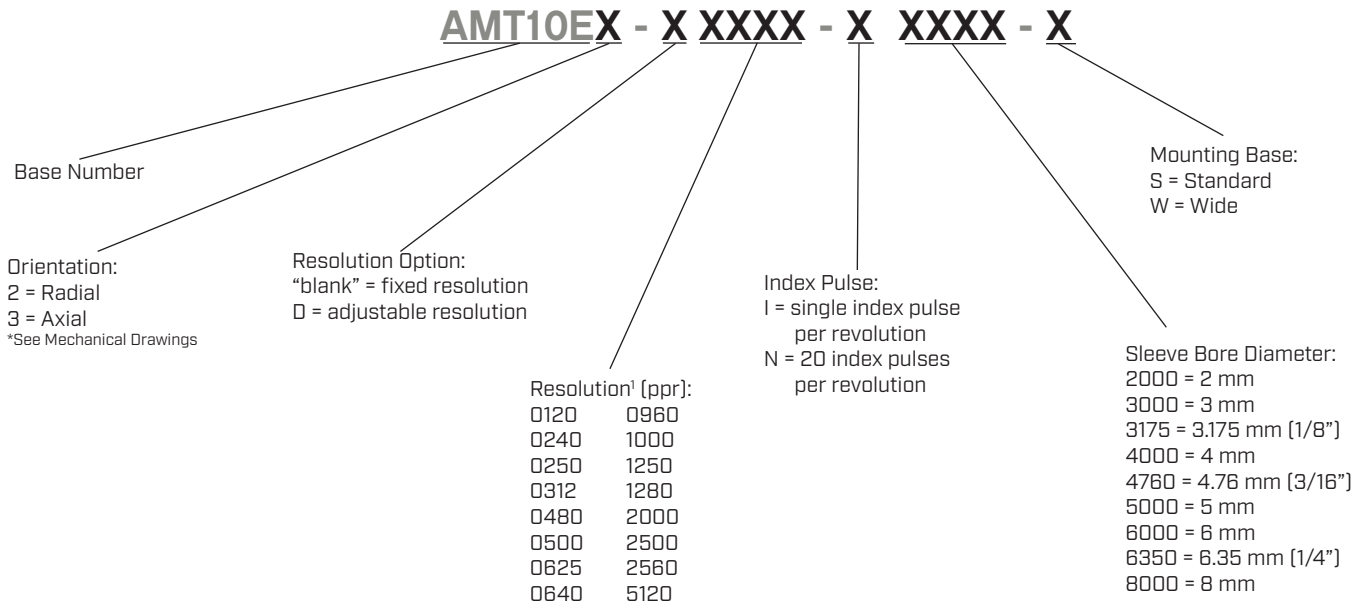

Note: 1. Fixed resolutions are permanently set at this value; adjustable resolutions are preset via DIP switch to this value upon shipment.

## AMT10E-V KITS

In order to provide maximum flexibility for our customers, the AMT10E series is provided in kit form standard. This allows the user to implement the encoder into a range of applications using one sku#, reducing engineering and inventory costs.

### ORDERING GUIDE

#### AMT10EX-V

Orientation:  
2 = Radial  
3 = Axial  
\*See Mechanical Drawings

SLEEVES								
2mm	3mm	1/8 inch (3.175mm)	4mm	3/16 inch (4.76mm)	5mm	6mm	1/4 inch (6.35mm)	8mm
Light Sky Blue	Orange	Purple	Gray	Yellow	Green	Red	Snow	Blue

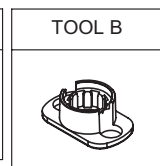
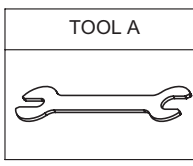
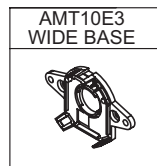
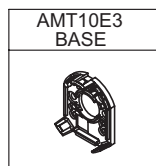
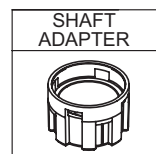
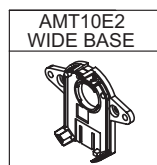
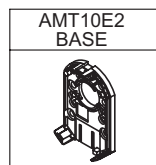

## RESOLUTION SETTINGS

1 = On, 0 = Off

Resolution (PPR)	Maximum RPM	1	2	3	4
5120	3000	0	0	0	0
2560	3000	0	0	1	0
2500	3000	1	0	0	0
2000	3000	0	1	0	0
1280	6000	0	0	0	1
1250	3000	1	0	1	0
1000	3000	0	1	1	0
960	3000	1	1	0	0
640	6000	0	0	1	1
625	6000	1	0	0	1
500	6000	0	1	0	1
480	3000	1	1	1	0
312.5	6000	1	0	1	1
250	6000	0	1	1	1
240	6000	1	1	0	1
120	6000	1	1	1	1

### DIP switch:

Example setting: 1250 PPR

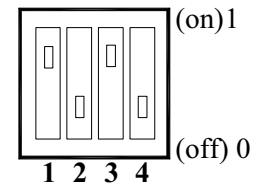

## ENCODER INTERFACE

CONNECTOR PINOUT		
Function		
#	AMT10E2	AMT10E3
B	B CHANNEL	B CHANNEL
5V	+5 V	+5 V
A	A CHANNEL	A CHANNEL
X	INDEX CHANNEL	INDEX CHANNEL
G	GND	GND

AMT10E2

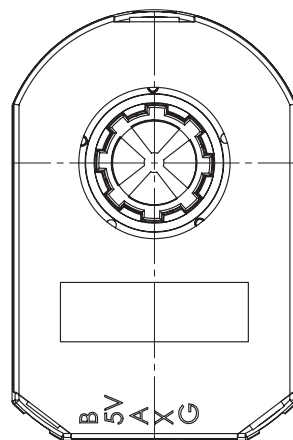

Mating Connector:  
Molex 50-57-9405 Housing  
Molex 16-02-0086 Terminals

AMT10E3

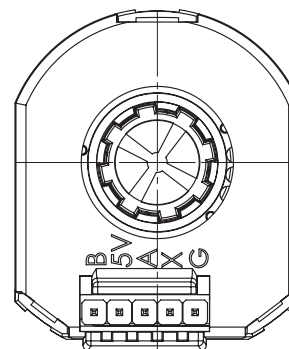

Mating Connector:  
AMP 3-640440-5 (tin)  
AMP 3-641237-5 (gold)

## MECHANICAL DRAWINGS

### AMT10E2 STANDARD BASE

units: mm[inch]  
tolerance: ±0.1mm

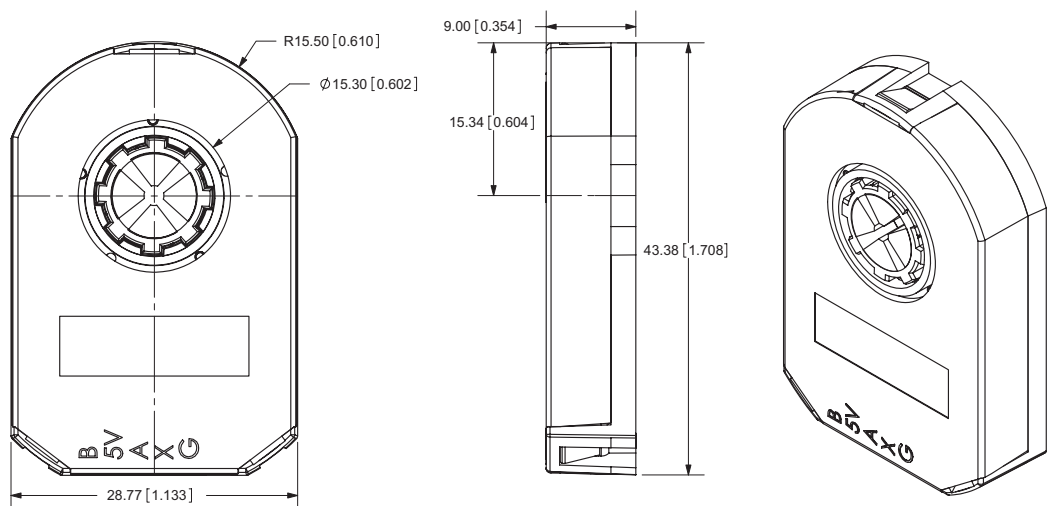

### AMT10E2 WIDE BASE

units: mm[inch]  
tolerance: ±0.1mm

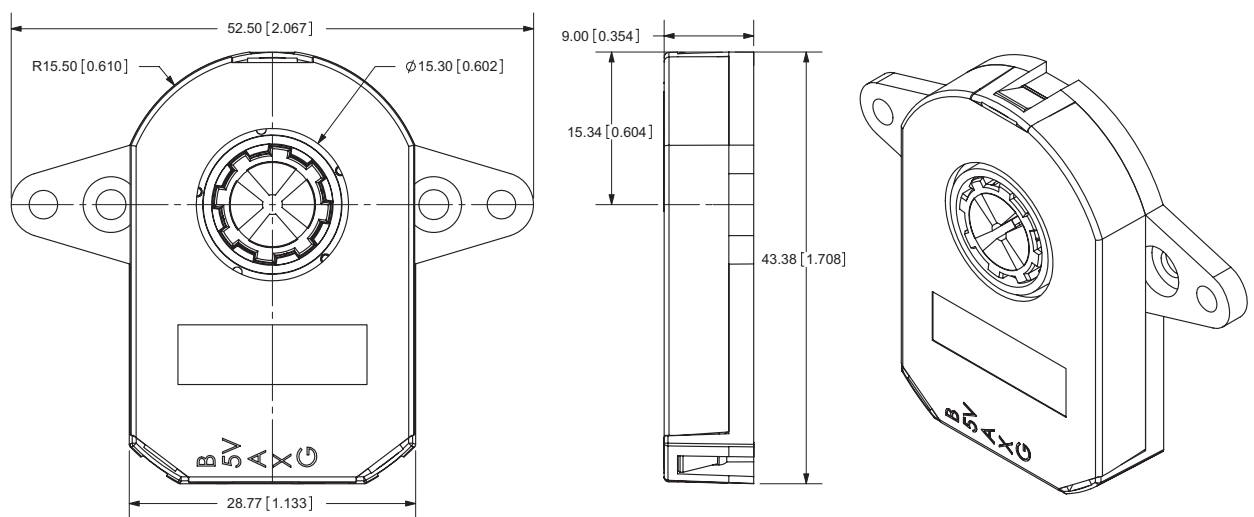

## MECHANICAL DRAWINGS (CONTINUED)

### AMT10E3 STANDARD BASE

units: mm[inch]  
tolerance:  $\pm 0.1\text{mm}$

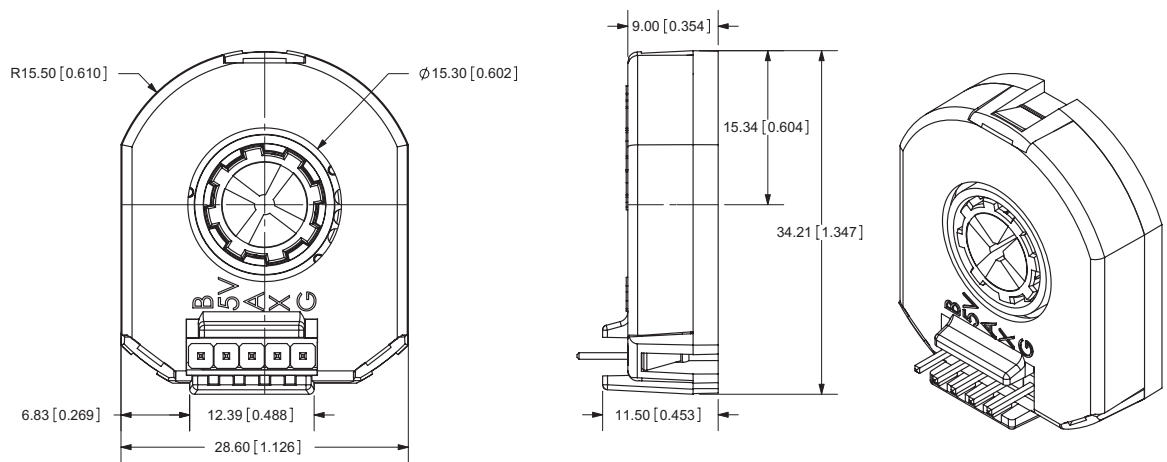

### AMT10E3 WIDE BASE

units: mm[inch]  
tolerance:  $\pm 0.1\text{mm}$

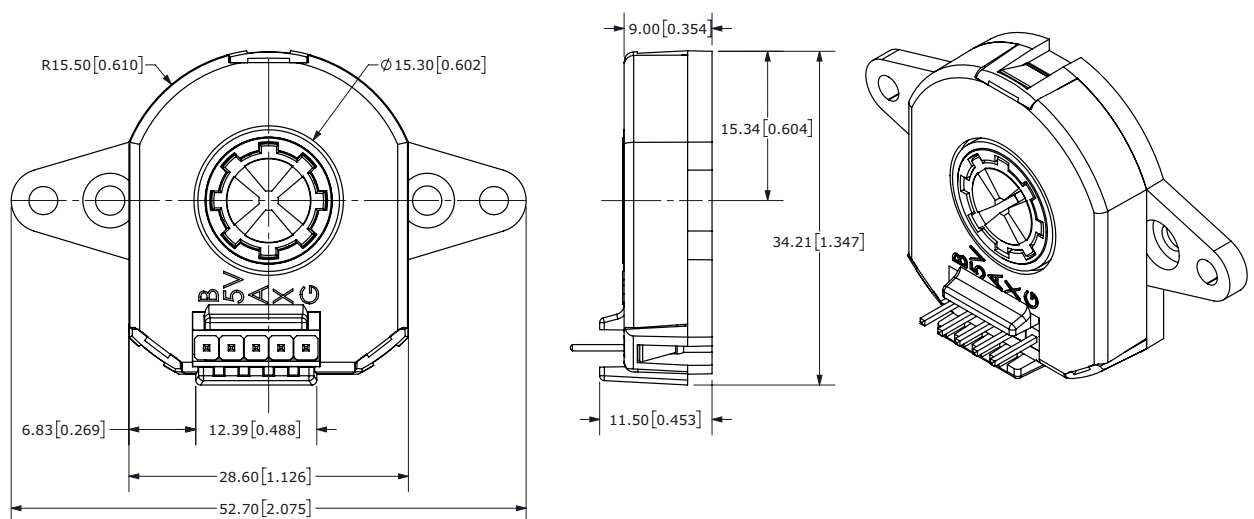

## MECHANICAL DRAWINGS (CONTINUED)

### MOUNTING HOLE PATTERNS

#### AMT 10E2 STANDARD BASE

units: mm[inch]  
tolerance: ±0.1

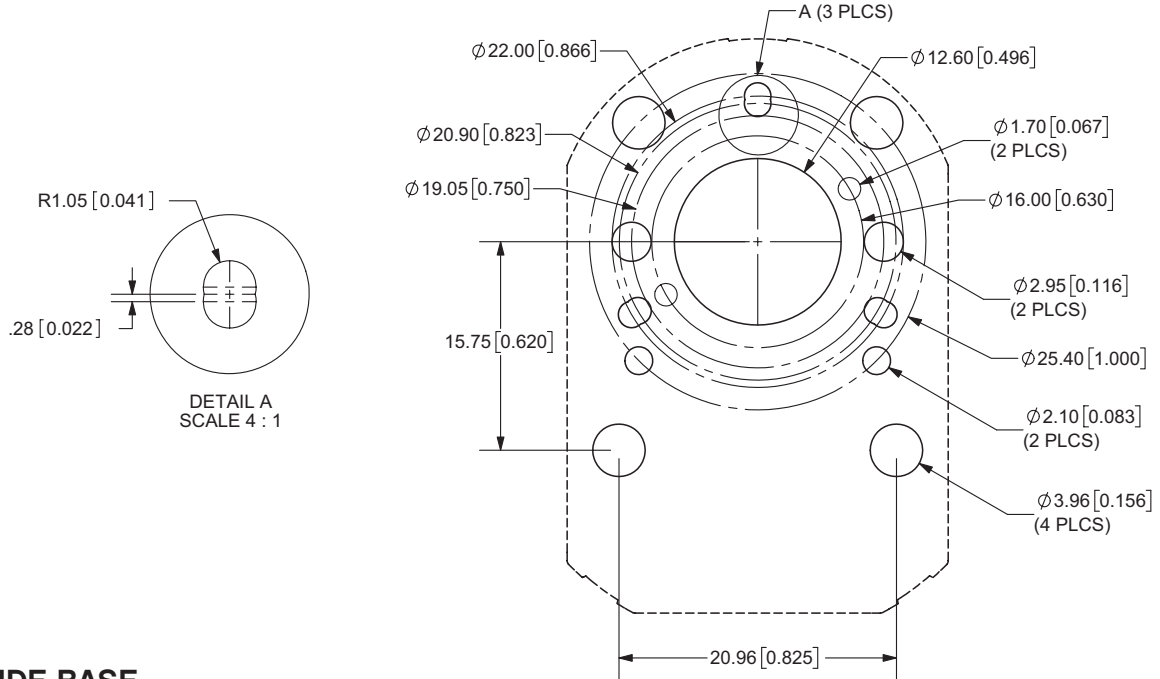

#### AMT10E2 WIDE BASE

units: mm[inch]  
tolerance: ±0.1

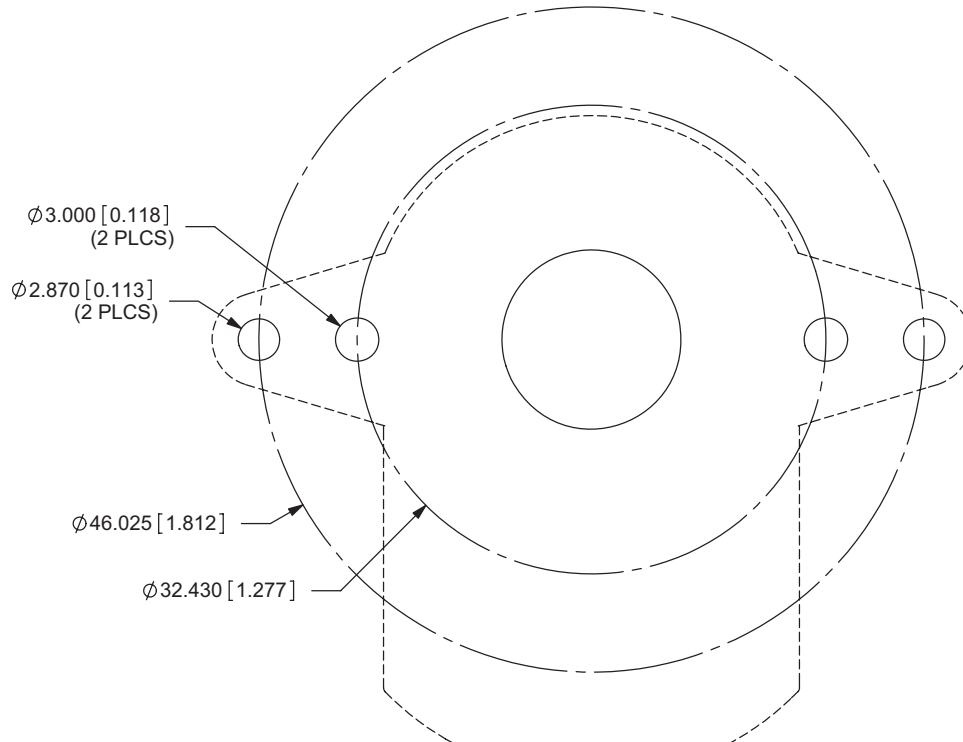

## MECHANICAL DRAWINGS (CONTINUED)

### MOUNTING HOLE PATTERNS

#### AMT 10E3 STANDARD BASE

units: mm[inch]  
tolerance: ±0.1

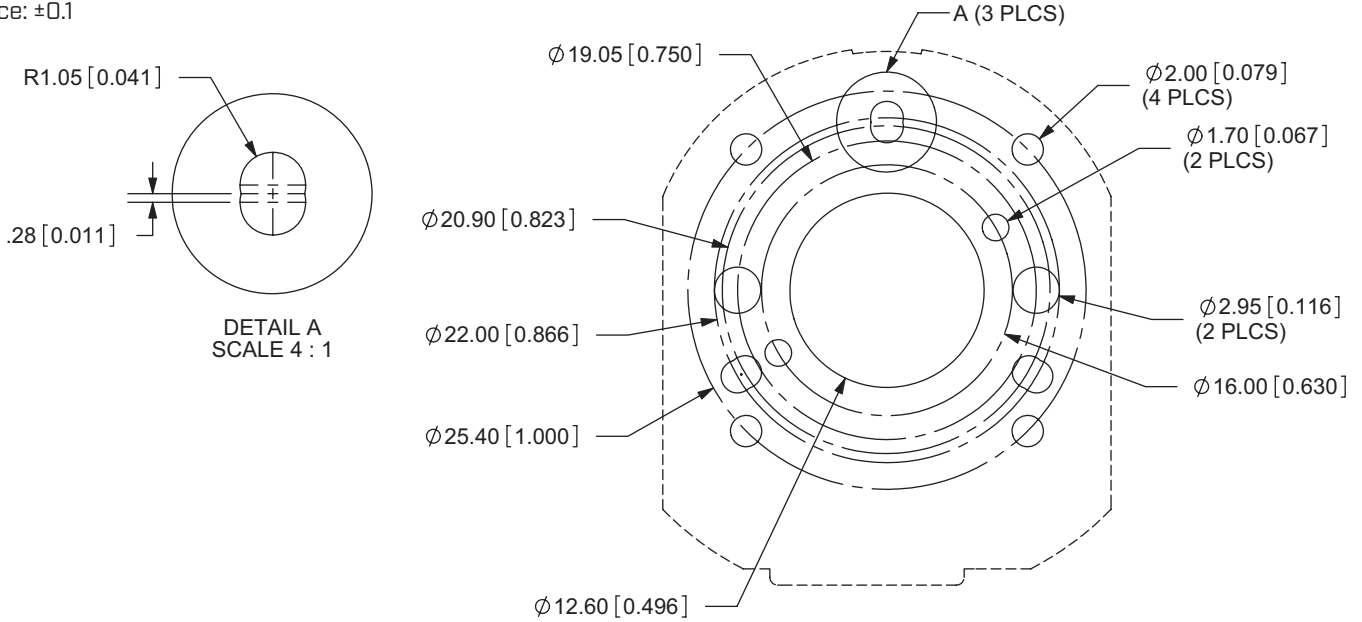

#### AMT10E3 WIDE BASE

units: mm[inch]  
tolerance: ±0.1

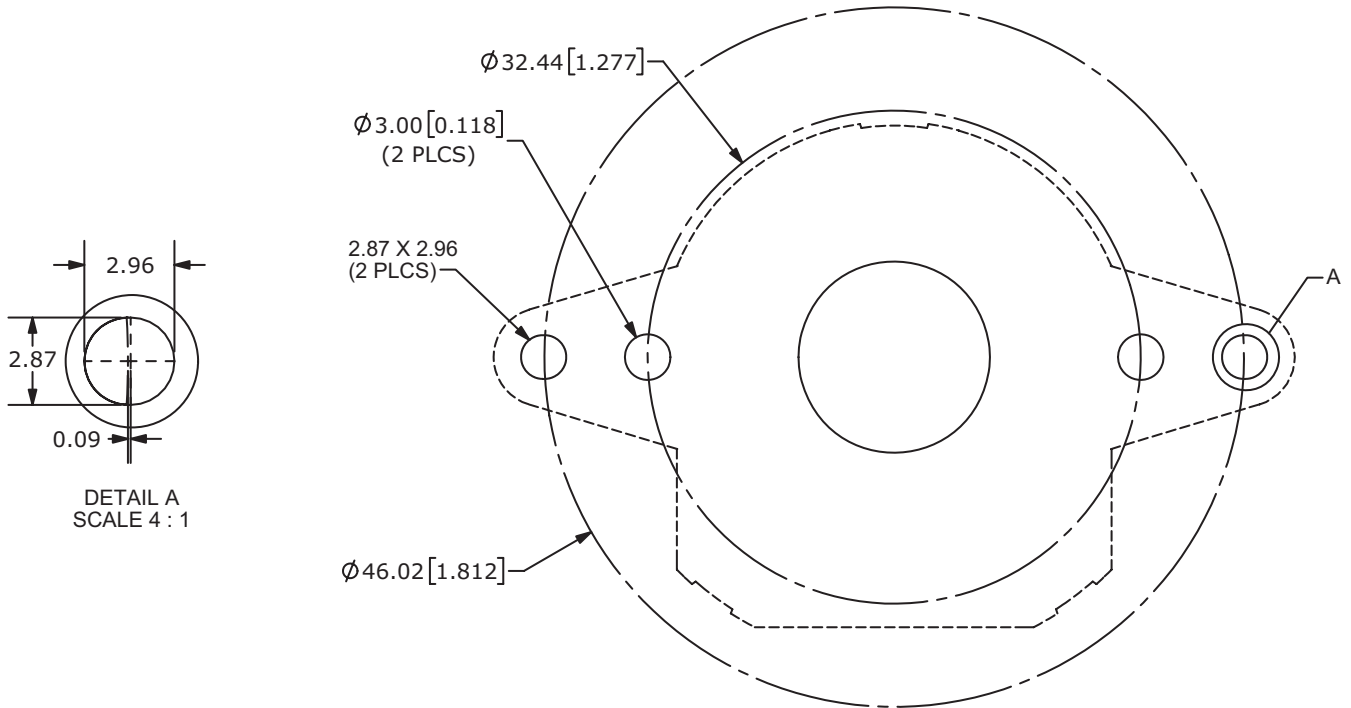



## ASSEMBLY PROCEDURE

### STEP 1

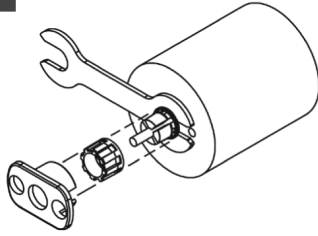

1. Insert Tool A as a spacer that defines the distance to the mounting surface.
2. Slide appropriate sized Sleeve over shaft all the way down to Tool A.
3. Slide Shaft Adaptor over Sleeve.
4. Use Tool B to press Shaft Adaptor over Sleeve until flush with Tool A.

### STEP 2

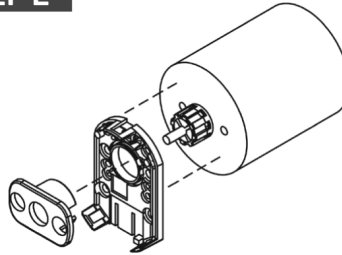

1. Remove Tools A and B.
2. Place Base on motor, with Tool B used as a centering tool.

### STEP 3

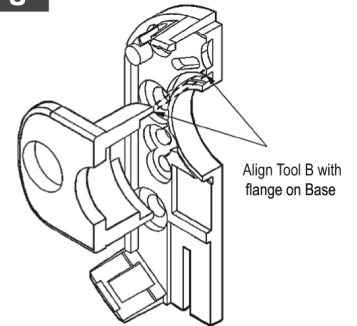

Align Tool B with flange on Base

1. Align Tool B with flange on Base.
2. Slide Base and Tool B onto motor, centering onto the Shaft Adapter.

### STEP 4

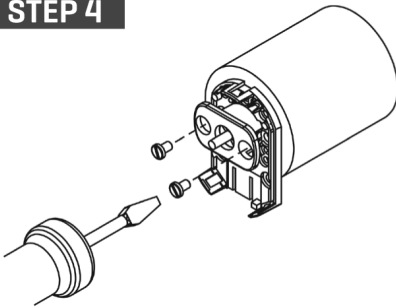

1. Fasten the Base on the motor.
2. Remove Tool B.

### STEP 5

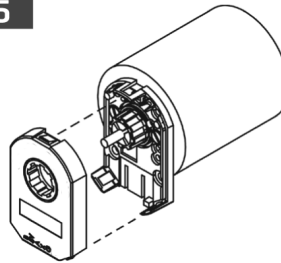

1. Slide the Top Cover onto the Base, carefully observing that the teeth of the Shaft Adaptor align with the grooves in the hub.\*

\* We recommend no more than three cycles of mounting and removal of the AMT top cover base. Multiple cycles of mounting and removing the top cover can cause base fatigue over time and affect encoder performance.

### STEP 6

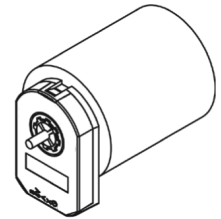

1. Make sure the snaps are fully engaged and the Top Cover is flush with the Base.
2. When assembly is finished, the Shaft Adaptor should be about flush with the front of the Encoder and the Motor Shaft should rotate freely.

## REVISION HISTORY

rev.	description	date
1.0	initial release	10/22/2020
1.01	added motor shaft tolerance details	08/04/2021
1.02	logo, datasheet style update	08/05/2022

The revision history provided is for informational purposes only and is believed to be accurate.



CUI Devices offers a one (1) year limited warranty. Complete warranty information is listed on our website.

CUI Devices reserves the right to make changes to the product at any time without notice. Information provided by CUI Devices is believed to be accurate and reliable. However, no responsibility is assumed by CUI Devices for its use, nor for any infringements of patents or other rights of third parties which may result from its use.

CUI Devices products are not authorized or warranted for use as critical components in equipment that requires an extremely high level of reliability. A critical component is any component of a life support device or system whose failure to perform can be reasonably expected to cause the failure of the life support device or system, or to affect its safety or effectiveness.

[cuidevices.com](http://cuidevices.com)