

SERIES: PR28 | **DESCRIPTION:** POWER RELAY**FEATURES**

- 20 amp
- 1 form A
- 1 form C
- class F

**MODEL**

	coil voltage typ [Vdc]	coil resistance [Ω±10%]	operating voltage ¹ min [Vdc]	release voltage max [Vdc]	continuous voltage max [Vdc]	coil power max [mW]
PR28-3V-360	3	25	2.25	0.3	3.3	360
PR28-5V-360	5	70	3.8	0.5	5.5	360
PR28-6V-360	6	100	4.5	0.6	6.6	360
PR28-9V-360	9	225	6.8	0.9	9.9	360
PR28-12V-360	12	400	9.0	1.2	13.2	360
PR28-15V-360	15	625	11.25	1.5	16.5	360
PR28-18V-360	18	900	13.5	1.8	19.8	360
PR28-24V-360	24	1,600	18.0	2.4	26.4	360
PR28-36V-360	36	3,600	27.0	3.6	39.6	360
PR28-48V-360	48	6,400	36.0	4.8	52.8	360

Notes: 1. Relay may pull in with less than operating voltage.
2. All specifications are measured at 23°C unless otherwise specified.

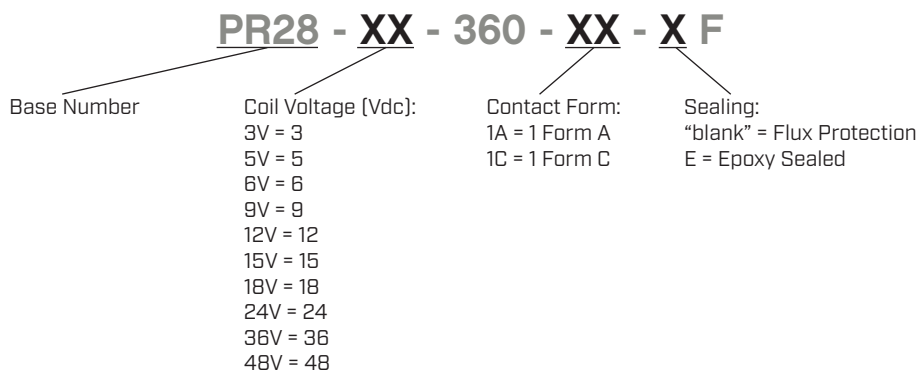
PART NUMBER KEY

COIL SPECIFICATIONS

parameter	conditions/description	min	typ	max	units
coil power	nominal		360		mW
	at pickup voltage		207		mW
temperature rise	at nominal coil voltage		42		K

CONTACT SPECIFICATIONS

parameter	conditions/description	min	typ	max	units
contact form	1 Form A, 1 Form C				
contact material	AgSnO ₂ (silver tin oxide)				
contact rating	1 Form A 17 A @ 277 Vac 12 A @ 250 Vac				
	1 Form C 17/10 A @ 277 Vac NO/NC				
contact resistance	at 1 A, 6 V, voltage drop method			100	mΩ
max switching voltage				277	Vac
				30	Vdc
max switching current	Vac			20	A
	Vdc			16	A
max switching power	Vac			4,700	VA
	Vdc			480	W
life	electrical: at 277 Vac, 16 A (1 Form A/1 Form C (NO), 7 A (1 Form C (NC)), resistive	100,000			operations
	mechanical	10,000,000			operations

GENERAL SPECIFICATIONS

parameter	conditions/description	min	typ	max	units
insulation resistance	at 500 Vdc, 23 °C, 50% RH	100			MΩ
dielectric strength	between coil and contacts at sea level for 1 minute		2,000		Vrms
operate time	at nominal coil voltage			10	ms
release time	at nominal coil voltage, without coil suppression			5	ms
shock resistance			10		G
vibration resistance	10-55 Hz, 1.5 mm double amplitude				
operating temperature	at nominal coil voltage	-40		85	°C
storage temperature	at nominal coil voltage	-40		130	°C
weight			9.5		g
safety approvals	UL/cUL 508				
flammability rating	UL94V-0				
RoHS	yes				
packaging	box: 100 pcs per box carton QTY: 1,000 pcs per carton				

SOLDERABILITY

parameter	conditions/description	min	typ	max	units
wave soldering	for max 5 seconds			260	°C
washable	only on epoxy sealed models max immersion time of 30 seconds			80	°C

MECHANICAL DRAWING (1A = 1 FORM A)

units: mm [inch]
 tolerance: ±0.254 mm
 unless otherwise noted

DESCRIPTION	MATERIAL	PLATING/COLOR
housing	PBT [UL94V-0]	white
terminals	copper alloy	tin

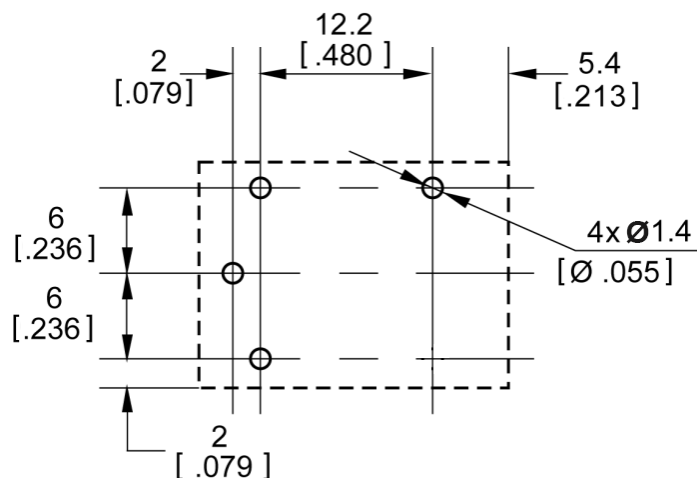
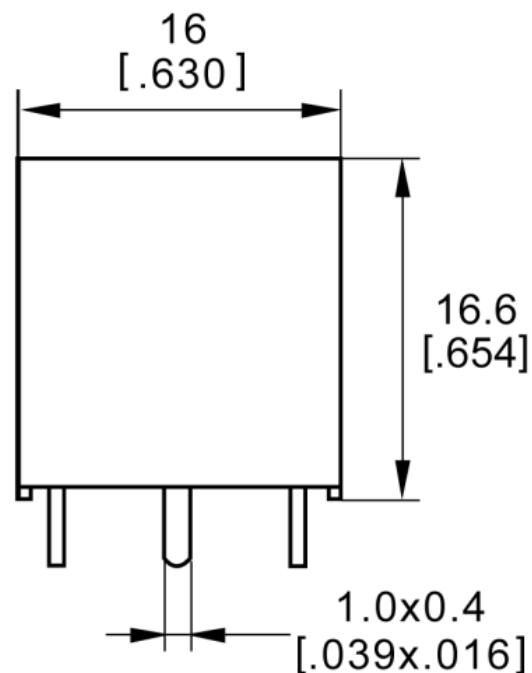
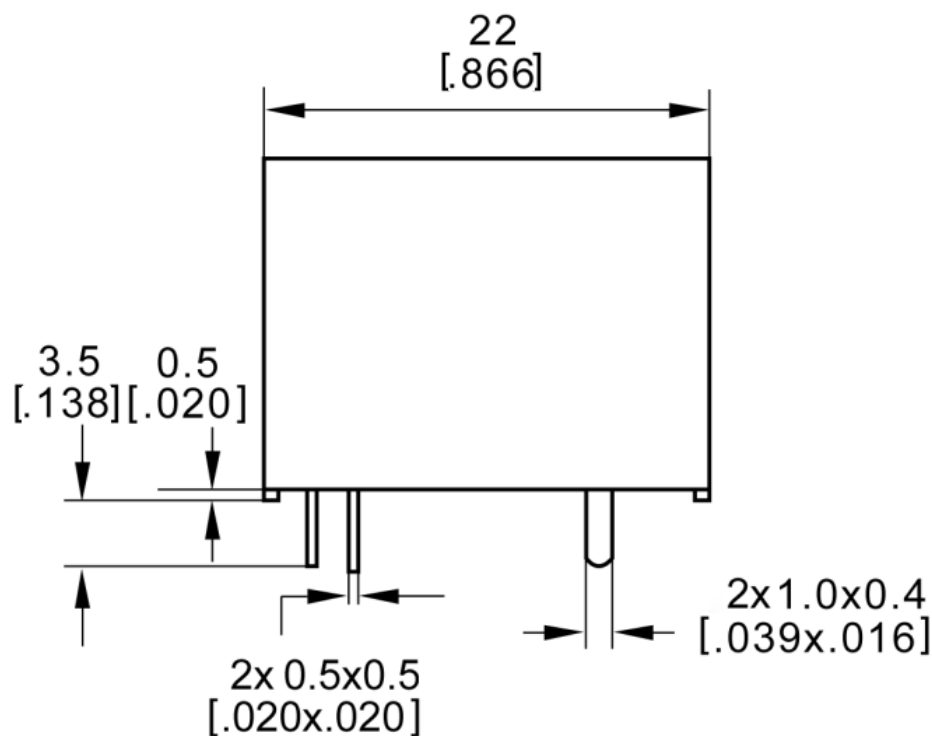

Recommended PCB Layout
 Bottom View

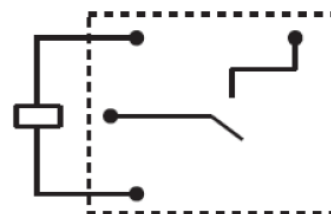

Wiring Diagram
 Bottom View

MECHANICAL DRAWING (1C = 1 FORM C)

units: mm [inch]
 tolerance: ±0.254 mm
 unless otherwise noted

DESCRIPTION	MATERIAL	PLATING/COLOR
housing	PBT [UL94V-0]	white
terminals	copper alloy	tin

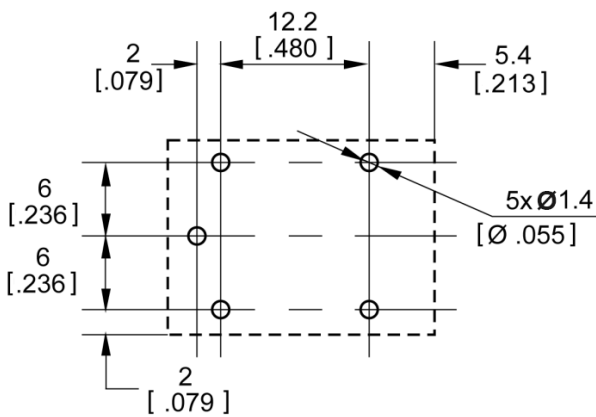
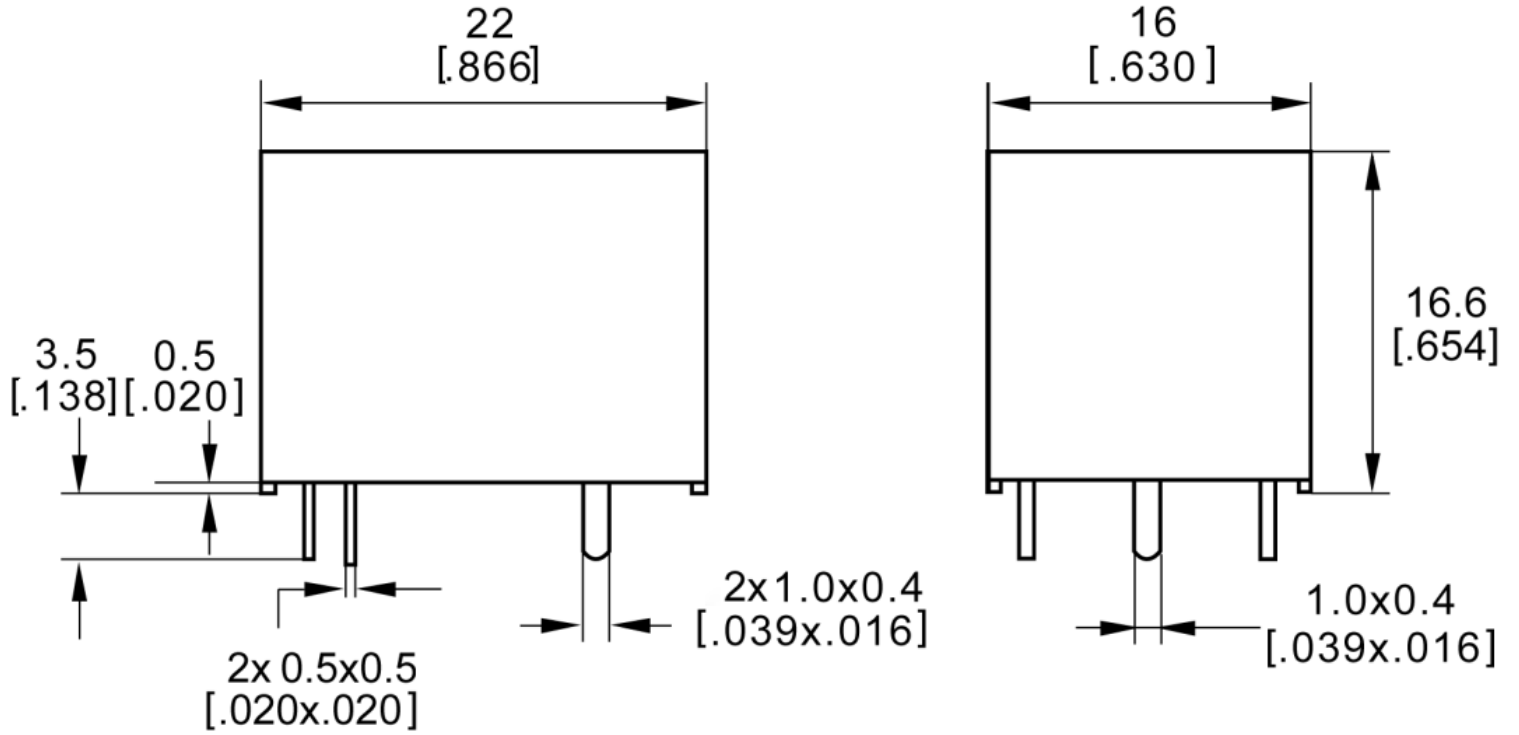

Recommended PCB Layout
 Bottom View

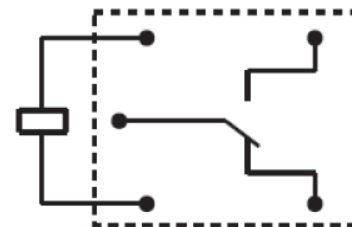

Wiring Diagram
 Bottom View

CHARACTERISTIC CURVES

Coil Temperature Rise

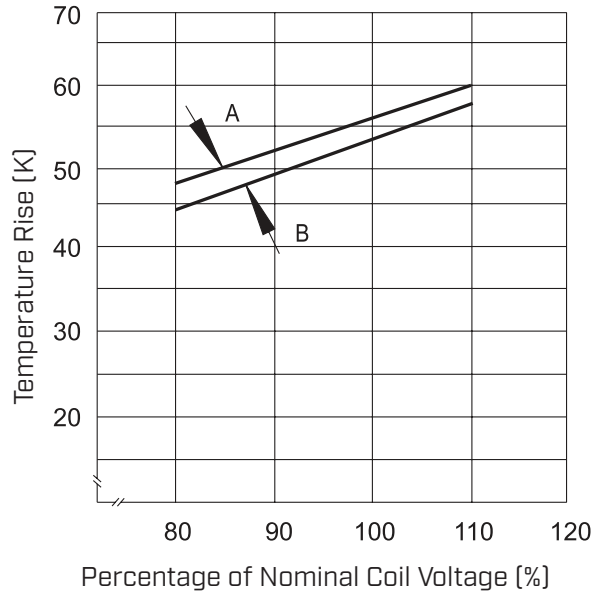

Test Conditions:
 Curve A: 20 A at 85°C
 Curve B: 16 A at 85°C
 Mounting Distance: 25 mm

Life Curve

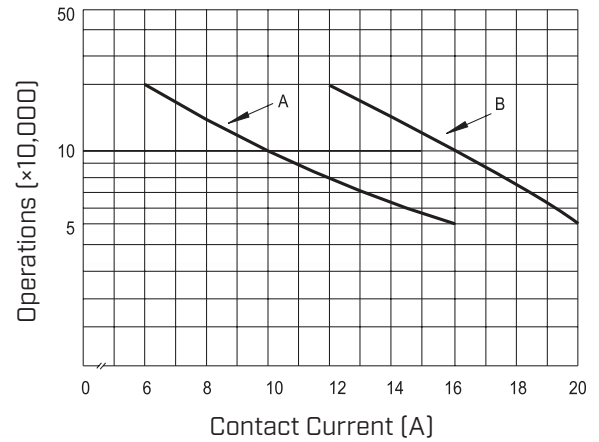

Test Conditions:
 Curve A: NO, resistive load, 85°C, flux protection, 16 A, 250 Vac, 1 second on 9 seconds off
 Curve B: NO, resistive load, 85°C, flux protection, 20 A, 250 Vac, 1 second on 9 seconds off

Maximum Switching Power

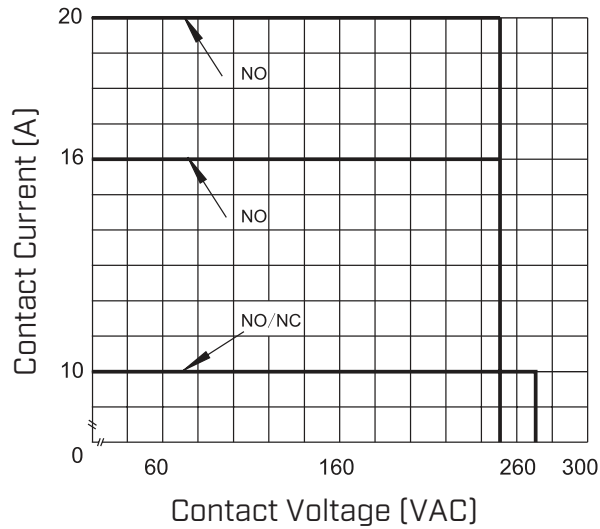

REVISION HISTORY

rev.	description	date
1.0	initial release	02/14/2024

The revision history provided is for informational purposes only and is believed to be accurate.



CUI Devices offers a one (1) year limited warranty. Complete warranty information is listed on our website.

CUI Devices reserves the right to make changes to the product at any time without notice. Information provided by CUI Devices is believed to be accurate and reliable. However, no responsibility is assumed by CUI Devices for its use, nor for any infringements of patents or other rights of third parties which may result from its use.

CUI Devices products are not authorized or warranted for use as critical components in equipment that requires an extremely high level of reliability. A critical component is any component of a life support device or system whose failure to perform can be reasonably expected to cause the failure of the life support device or system, or to affect its safety or effectiveness.

cuidevices.com